

Building Air-Conditioners Control System

LM ADAPTER

Model : LMAP03U

Installation Manual

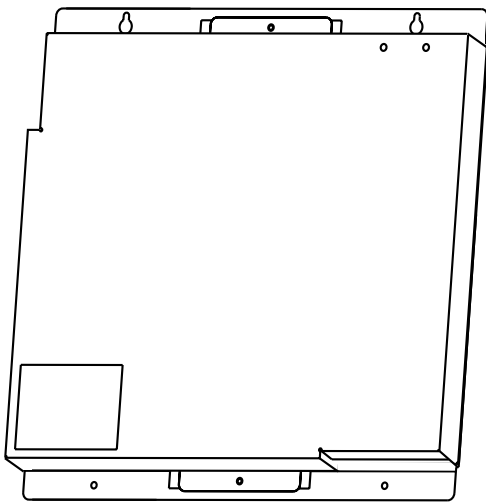

Before using the unit, please read this Installation Manual carefully to ensure correct operation. Store this Installation Manual in a location that is easy to find. Echelon®, LON®, LONWORKS®, Neuron®, 3150® and the Echelon logo are trademarks of Echelon Corporation registered in the United States and other countries. LonMaker™ and the Lon Users logo are trademarks of Echelon Corporation.



Contents

Safety precautions.....	1,2
1. Parts Include	3
2. Specifications	3
2-1 External View	3
2-2 Environment Specifications	3
2-3 Connected Air Conditioning Equipment	4
2-4 LONWORKS® Network Specifications	4
2-5 List of LM ADAPTER Functions	4
3. Installation	5
3-1 Locally Procured Parts	5
3-2 Installation Method	6
3-3 Wiring Methods	7
3-4 Electrical Wiring	8
4. System Settings.....	10
4-1 If not used together with system controller.....	10
4-2 If used together with system controller.....	11
4-3 Initialization Settings of LONWORKS® Network	12
5. Confirming Operation	13
5-1 Flow of Onsite Adjustments.....	13
5-2 Preparation Material for Onsite Adjustments	13
5-3 Preparation and Setting	13
5-4 Test Run.....	14
6. Troubleshooting.....	14
6-1 Abstract	15
6-2 Troubleshooting	16
6-3 Error Code list	18
Appendix : Test run check sheet	19

Safety Precautions



- Before installing this unit, make sure you read all the “Safety Precautions”.
- This manual describes the installation of LM ADAPTER and wiring to the outdoor unit.
- Please read the installation manual of air-conditioning units with regards to the installation method of air-conditioning units.
- The “Safety Precautions” provide very important points regarding safety. Make sure you follow them.

Symbols and Terms

 WARNING	Statements identify condition or practices that could result in personal injury or loss of life.
 CAUTION	Statements identify condition or practices that could result in damage to the unit or other property.

- After reading this installation manual, keep it in a place where the final user can see it anytime he or she wants to it. When someone moves, repairs or uses the LM ADAPTER, make sure that this manual is forwarded to the final user.

Symbols used in the illustrations

-  : Indicates a part which must be grounded.
-  : Beware of electric shock. (This symbol is displayed on the main unit label) <Color: Yellow>
For servicing, shut down the power supply for LM ADAPTER.

WARNING

Ask your dealer or technical representative to install.

Any deficiency caused by your own installation may result in an electric shock and fire.

Install in a place which is strong enough to withstand the weight of the unit

Any lack of the strength may cause the unit to fall down, resulting in a personal injury.
Any deficiency caused by installation may result in an electric shock, fire or incorrect operation.

Wire and connect using the desired cables securely so that any external force exerted on the cable is not imparted on to the terminal connections.

Imperfect connection and fixed may result in heating or fire.

Never modify or repair the unit by yourself.

Any deficiency caused by your modification or repair may result in an electric shock or fire. Consult with your distributor for repair.

Make sure that the unit is powered by a dedicated line.

Other appliances connected to the same line could cause an overload.

If it is assumed that moisture advances into the unit, such as the time of rainy weather, do not perform any work on electric circuits.

It may become the cause of damage of a fire and the unit by an electric shock or corrosion.

Ensure that installation work is done correctly following that installation manual.

Any deficiency caused by installation may result in an electric shock or fire.

All electrical work must be performed by a licenced technician, according to local regulations and the instructions given in this manual.

Any lack of electric circuit or any deficiency caused by installation may result in an electric shock or fire.

Securely install the cover (panel) of the LM ADAPTER.

If the cover (panel) is not installed properly, dust or water may enter the unit and fire or electric shock may result.

Do not move and re-install the unit yourself.

Any deficiency caused by installation may result in an electric shock or fire. Ask your distributor or special vender for moving and installation.

Make sure that there is a main power switch.

A ready accessible breaker for power source line helps reduce the risk of electric shocks. Installation of a breaker is mandatory in same areas.

CAUTION

Do not install the unit where combustible gas may leak.

If the gas leaks and accumulates around the unit, an explosion may result.

Do not use in any special environment.

Using in any place exposed to oil(including machine oil), steam and sulfuric gas may deteriorate the performances significantly or given damage to the component parts.

Do not wash with water.

Doing so may cause an electric shock or a malfunction.

Do not install in any steamy place such as bath room or kitchen.

Avoid any place where moisture is condensed into dew. Doing so may cause an electric shock or a malfunction.

Do not install in any place at a temperature of more than 43 °C (109°F) or less than -15°C (5°F) .

It may become the cause of modification and failure.

Safely dispose of the packing materials.

Tear apart and throw away plastic packaging bags so that children will not play with them. If children play with a plastic bag which was not torn apart, they face the risk of suffocation.

Be sure to shut off the power source of the unit and all the other units to connected to the unit before wiring.

Doing so may cause an electric shock or a malfunction.

This appliance must be grounded.

Make sure to install a grounding line. Do not connect the grounding line to gas or water pipes, lightning conductors or telephone grounding lines. Improper grounding may cause an electric shock.

Do not band together or install in the same metal pipe, the power supply line and transmission line.

Doing so may cause a malfunction of unit.

When installing the unit in a hospital, communication station, or similar place, provide sufficient protection against noise.

Inverter equipment, private power generator, high-frequency medical equipment, or radio communication equipment may cause the air conditioner to operate erroneously, or fail to operate. On the other hand, the air conditioner may affect such equipment by creating noise that disturbs medical treatment or image broadcasting.

Do not touch any PCB(Printed Circuit Board) with your hand or tools. Do not allow dust to collected on the PCB.

Doing so may cause an electric shock or fire.

Do not install in any place where acidic or alkaline solution or special spray or other similar substances are used.

Doing so may cause an electric shock or a malfunction.

Never connect the power source to the transmission line.

Doing so may caused a malfunction or a failure.

Use only an earth leakage breaker and fuse of the specified capacity.

If no earth leakage breaker is installed, it may cause an electric shock.

Using fuse and wire or copper wire with too large a capacity may cause a malfunction to the unit or fire.

Use standard wires in compliance with the current capacity.

A failure to do this may result in an electric leakage, heating or fire.

Wire so that it wires do not received any tension.

Tension may caused wire breakage, heating or fire.

Do not touch the switches with wet fingers.

Touching a switch with wet fingers can cause electric shock.

1. Parts Include

Verify that the following parts are appended to the product.

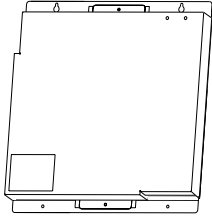
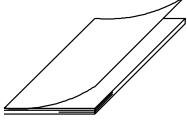
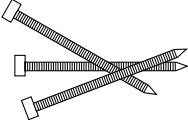
Name	Main Unit	Installation manual	Binding band
Shape			
Quantity	1	1	3

- The external interface file (XIF) is necessary for the product.
- Upon verifying the 16-digit program ID (PID) which is bonded on the board, please contact your dealer.

2. Specifications

2-1 External View

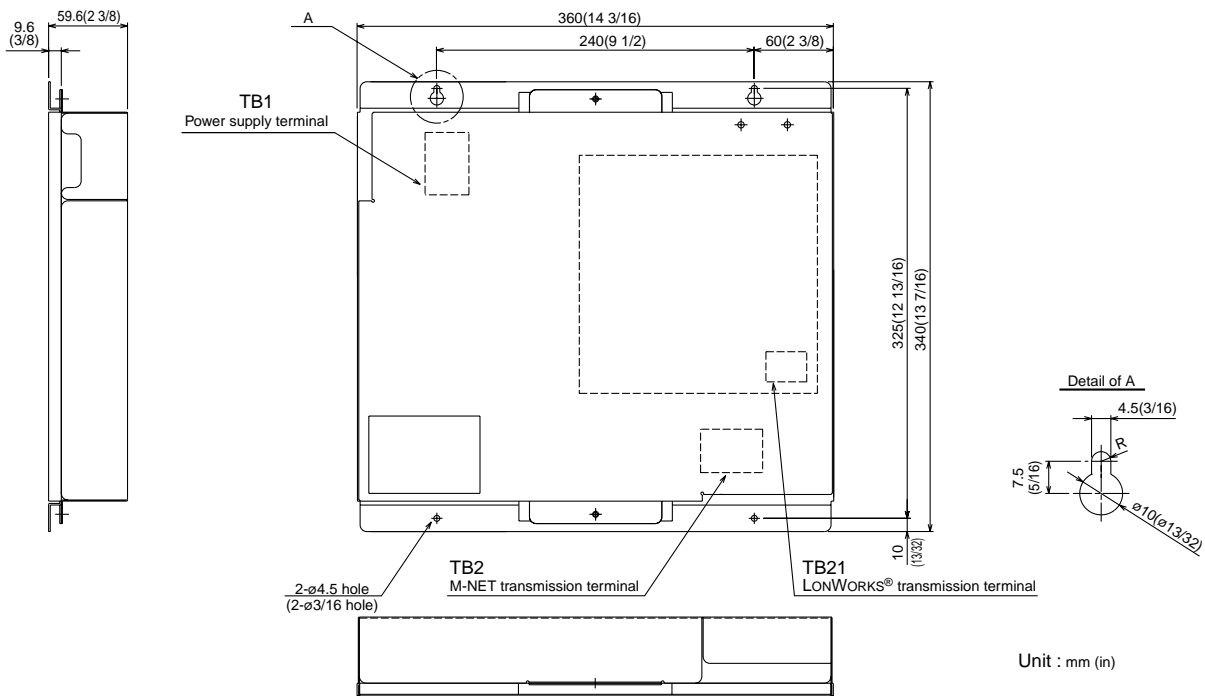

2-2 Environment Specifications

Item		Description	
Dimensions		340 (H) x 360 (W) x 59.6 (D) mm / 13 7/16 (H) x 14 3/16 (W) x 2 3/8 (D) in	
Net Weight		3.4 kg / 7 1/2 lb	
Power Source		~ 208 - 230V (60 Hz)	
Current Consumption		50 mA (Maximum)	
Operation Environment	Temperature	Operating Range	-15 to 43°C / 5 to 109°F
		Storage Range	-20 to 60°C / -4 to 140°F
Humidity		30 to 95 RH (No condensation)	
Installation Environment		In the control panel box	

2-3 Connected Air Conditioning Equipment

Item	Description
Connected Equipment	MITSUBISHI ELECTRIC Multiple split type air conditioners CITY MULTI Split-type air conditioners Mr.SLIM Heat recovery ventilators LOSSNAY (* For details of the connected models, please contact your dealer.)
Number of Units	LM ADAPTER can control 50 indoor units (including LOSSNAY)

2-4 LONWORKS® Network Specifications

Item	Description	
Neuron CHIP	TMPN3150 (10MHz)	
Network Transceiver	FTT-10A (Free Topology 78kbps)	
Performance	Average communication capacity	2.5 inputs/second
	Peak communication capacity	50 inputs/second (for one second)

* The proper communication is not obtainable when communication intervals exceed its performance, assure sufficient intervals.

* ACK Service is recommended for the network service.

* Detailed specifications for the LONWORKS® network can be found in “FTT-10A Free Topology Transceiver User's Guide” by Echelon Corporation.

2-5 List of LM ADAPTER Functions

Functions

Name	input	output
On/Off	✓	✓
Set Point from network (Both cool and heat)	✓	✓
Mode	✓	✓
Fanspeed	✓	✓
Indoor temperature state	—	✓
Local Prohibit On/Off	✓	✓
Local Prohibit mode	✓	✓
Local Prohibit SetPoint	✓	✓
Thermostat Off	✓	✓
Filter sign	✓ (Reset)	✓
Thermo On/Off state	—	✓
Model Size	—	✓
Alarm state	—	✓
Error Code	—	✓
Error Address	—	✓

3. Installation

<Notes>

Read and understand the contents of Chapter 1 "Safety Precautions " before performing the installation.

3-1 Locally Procured Parts

Prepare the following prior to installing the unit.

Locally procured parts	Contents																														
Power wire and ground wire	Use sheathed vinyl cord or wire. Wire type Wire should not be lighter than ordinary PVC sheathed flexible cord IEC 60227 (designation 60227 IEC 53) Wire size 0.75mm ² to 1.25mm ² (AWG18 to 16)																														
M-NET transmission wire	Use the sheathed vinyl cord or wire. Wire type CPEVS, CVVS or equivalent" Wire size Solid wire : ϕ 1.2mm to ϕ 1.6mm Twist type : 1.25mm ² to 2mm ² (AWG16 to 14)																														
LONWORKS [®] Network transmission wire	Use the wire which is recommended by Echelon Corporation. For details, refer to "FTT-10A Free Topology Transceiver User's Guide". For reference, Cable Types and Typical Parameters. <table border="1" style="width: 100%; border-collapse: collapse;"> <thead> <tr> <th>Cable type</th> <th>Wire dia /AWG</th> <th>Rloop Ω/km</th> <th>C nF/km</th> <th>Vprop % of C</th> </tr> </thead> <tbody> <tr> <td>Belden 85102, single twisted pair, stranded 19/29, unshielded, 150°C</td> <td>1.3mm/16</td> <td>28</td> <td>56</td> <td>62</td> </tr> <tr> <td>Belden 8471, single twisted pair, stranded 19/29, unshielded, 60°C</td> <td>1.3mm/16</td> <td>28</td> <td>72</td> <td>55</td> </tr> <tr> <td>Level IV 22AWG, twisted pair, typically solid & unshielded</td> <td>0.65mm/22</td> <td>106</td> <td>49</td> <td>67</td> </tr> <tr> <td>JY(St) Y 2X2X0.8, 4-wire herical twist, solid, shielded</td> <td>0.8mm/20.4</td> <td>73</td> <td>98</td> <td>41</td> </tr> <tr> <td>TIA568A category 5 24AWG, twisted pair</td> <td>0.51mm/24</td> <td>168</td> <td>46</td> <td>58</td> </tr> </tbody> </table> <p>If a shielded cable is used, the shield should be connected to earth ground via a single 470kΩ, 1/4 W, \leq10%, metal film resistor to prevent static charge build-up.</p>	Cable type	Wire dia /AWG	Rloop Ω /km	C nF/km	Vprop % of C	Belden 85102, single twisted pair, stranded 19/29, unshielded, 150°C	1.3mm/16	28	56	62	Belden 8471, single twisted pair, stranded 19/29, unshielded, 60°C	1.3mm/16	28	72	55	Level IV 22AWG, twisted pair, typically solid & unshielded	0.65mm/22	106	49	67	JY(St) Y 2X2X0.8, 4-wire herical twist, solid, shielded	0.8mm/20.4	73	98	41	TIA568A category 5 24AWG, twisted pair	0.51mm/24	168	46	58
Cable type	Wire dia /AWG	Rloop Ω /km	C nF/km	Vprop % of C																											
Belden 85102, single twisted pair, stranded 19/29, unshielded, 150°C	1.3mm/16	28	56	62																											
Belden 8471, single twisted pair, stranded 19/29, unshielded, 60°C	1.3mm/16	28	72	55																											
Level IV 22AWG, twisted pair, typically solid & unshielded	0.65mm/22	106	49	67																											
JY(St) Y 2X2X0.8, 4-wire herical twist, solid, shielded	0.8mm/20.4	73	98	41																											
TIA568A category 5 24AWG, twisted pair	0.51mm/24	168	46	58																											
Screw	To install the main body, prepare four M4 screws which are suitable for the installation area.																														
Main Power Switch (Circuit Breaker)	<table border="1" style="width: 100%; border-collapse: collapse;"> <thead> <tr> <th>Breaker for wiring</th> <th>Breaker for Current Leakage</th> </tr> </thead> <tbody> <tr> <td style="text-align: center;">3A</td> <td style="text-align: center;">3A 30mA 0.1 sec or less</td> </tr> </tbody> </table> <p>Use a breaker with a contact distance of 3mm or more.</p>	Breaker for wiring	Breaker for Current Leakage	3A	3A 30mA 0.1 sec or less																										
Breaker for wiring	Breaker for Current Leakage																														
3A	3A 30mA 0.1 sec or less																														

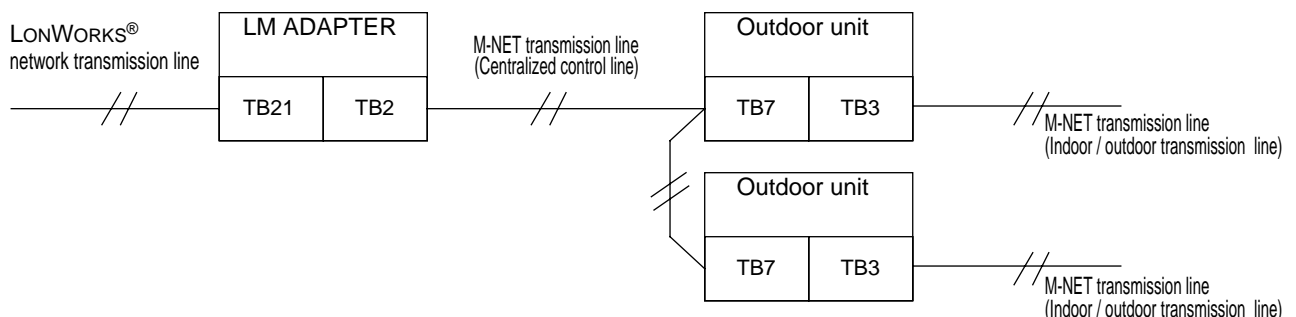

3-2 Installation Method

- LM ADAPTER is not waterproof type.
- LM ADAPTER shall be installed in a control panel box (steel : thickness 1 mm (3/64 in) or more).
Please prepare the control panel box in consideration with installation space as shown in the Fig.
(Install in an area capable of withstanding a 3.4 kg (7 1/2 lb) load.)
The unit shall be also installed in vertical direction only indicated by arrow making on the cover as shown in the Fig.
- Use M4 screws as shown in Fig. below to fix the product.
To prevent the product from falling, make sure to fix at four places.

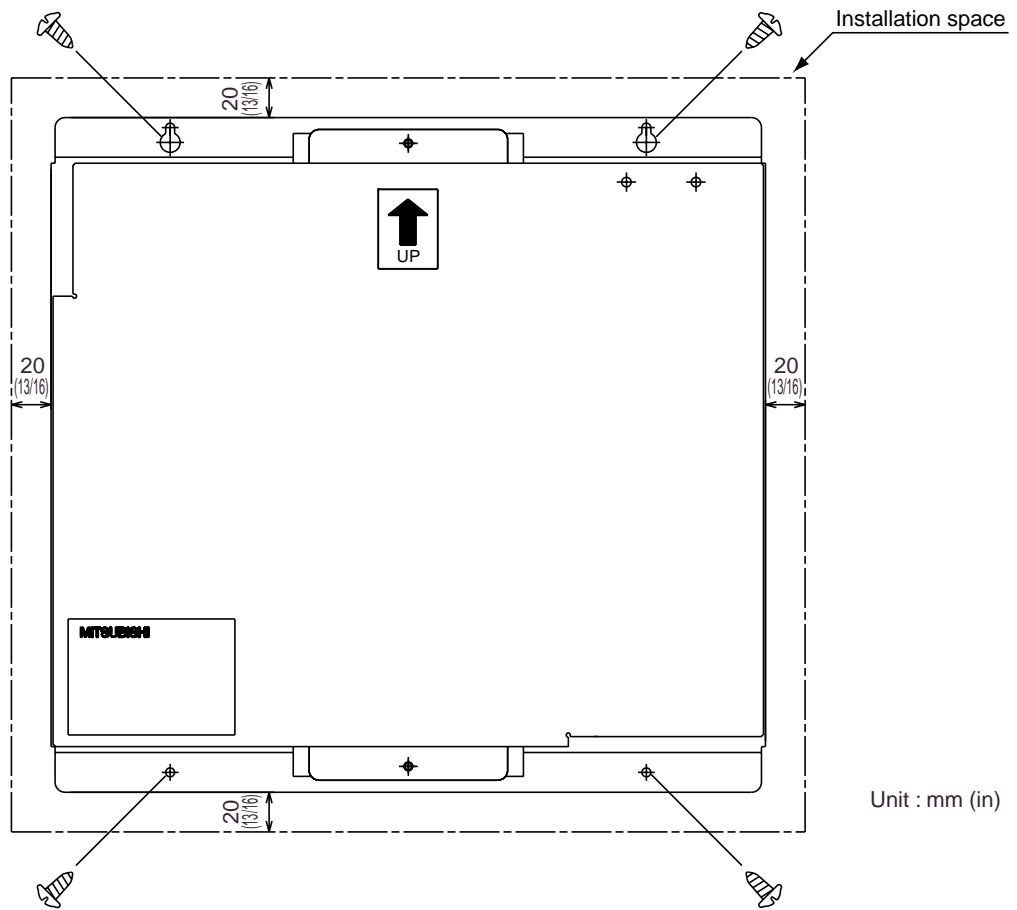

3-3 Wiring Methods

Use wire clamps provided to secure the wires and prevent external force from being conveyed by the wire to the wire connections.

* External force could cause deformation or damage to the terminal blocks.

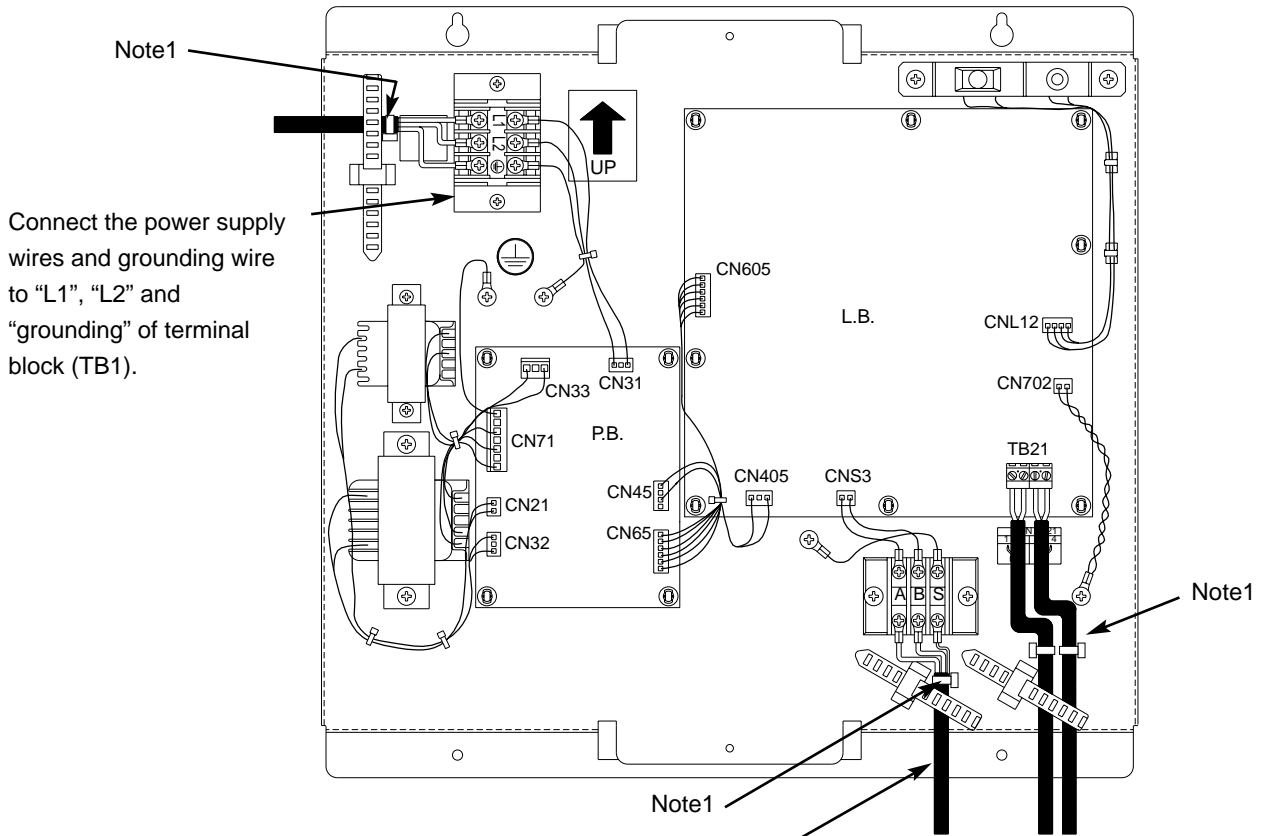

Connect the power supply wires and grounding wire to "L1", "L2" and "grounding" of terminal block (TB1).

Connect M-NET signal wire to "A" and "B" of terminal block (TB2).

- Connect the M-NET transmission wire to transmission terminal block (TB7) of the centralized control.

Connect LONWORKS® signal wire to "1", "2" or "3", "4" of signal wire terminal block (TB21).

- TB21-"1" and "3" as well as "2" and "4" of TB21 are connected inside the circuit board.

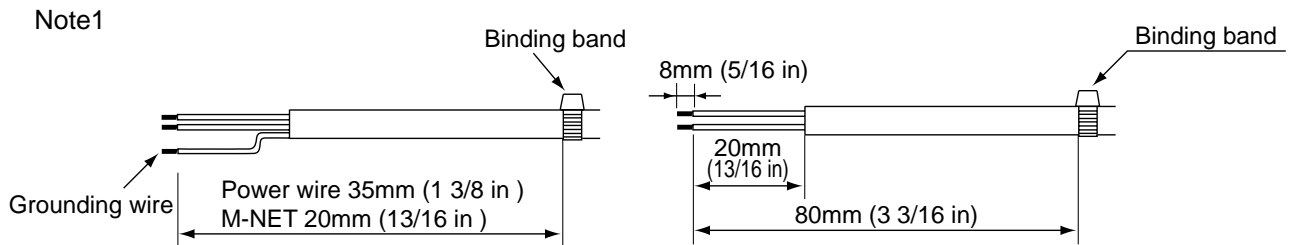

For power wire and M-NET transmission wire

For LONWORKS® transmission wire

Attach the appended binding band to the power wire and transmission wire, and fasten it, positioning the area at inner side than the wire clamp.

Make sure that the ground wire is longer than the other wires.

Use a small screwdriver to connect diameter 0.2 to 2.5 mm² (AWG24 to 12) cable for terminal block (TB21) on the unit. Tightening torque is 0.5 to 0.6 Nm. Up to two wires can be connected to one terminal block.

3-4 Electrical Wiring

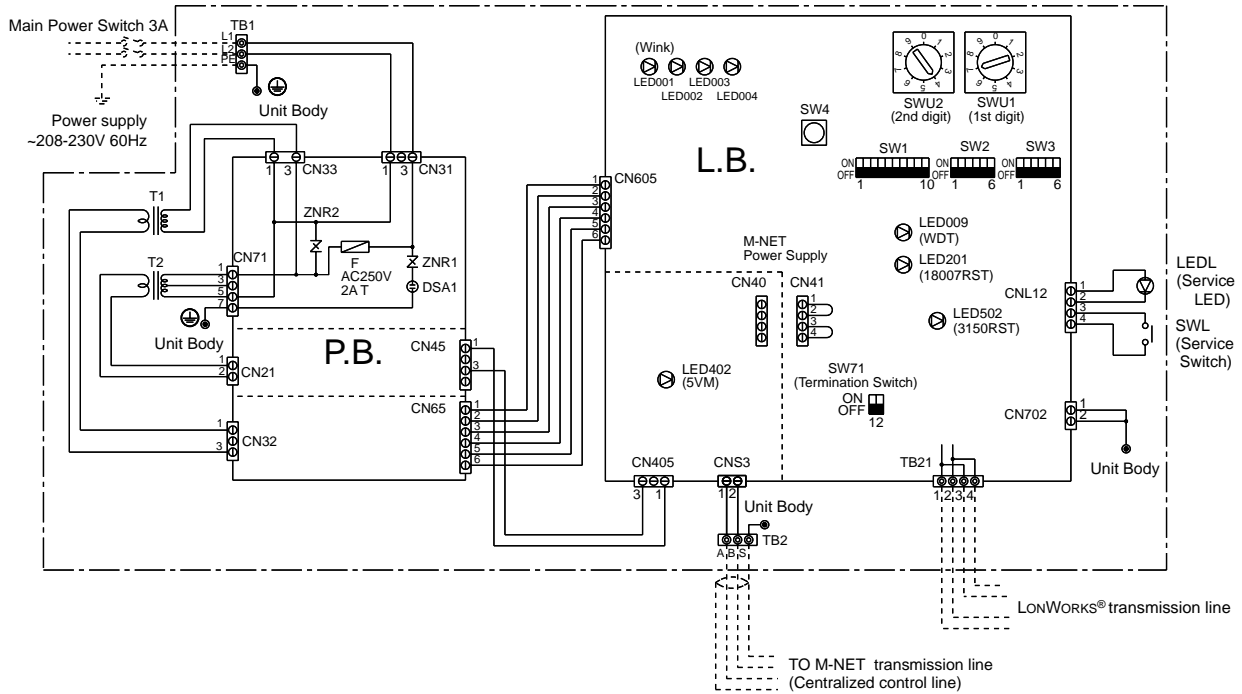

SYMBOL EXPLANATION

SYMBOL	NAME	
L.B	LM ADAPTER main board	
P.B	Power circuit board	
F	Fuse AC250V 2A T	
T1.2	Transformer	
SW1, 2, 3	Switch	Function selection
SW71		Termination selection switch (LONWORKS®)
SWU1, 2	Switch	M-NET address switch
SWL		Service switch (LONWORKS®)

SYMBOL	NAME	
LED001 - 004	LED	Maintenance LED Use LED001 as Wink (LONWORKS®) at SW2-1 - 6 OFF
LED009/201/502/402		Status LED
LEDL	Terminal block	Service LED (LONWORKS®)
TB1		Power source
TB2		M-NET transmission line
TB21	Terminal block	LONWORKS® transmission line
CN40/CN41		Power Supply switch connector
⊕	Grounding terminal	

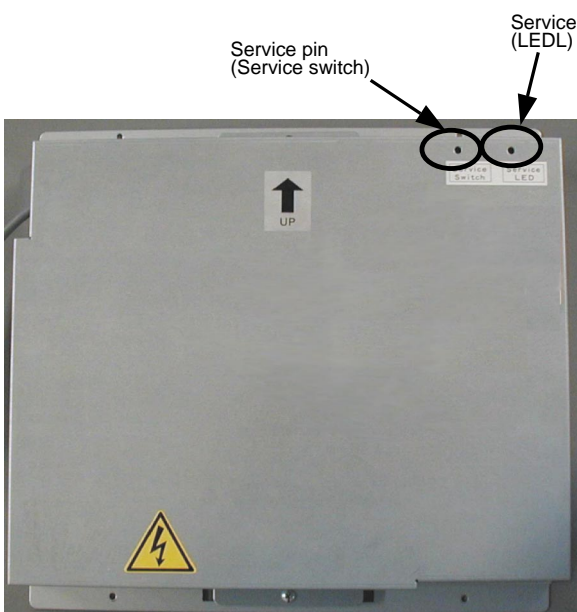

[Exterior of LM ADAPTER]

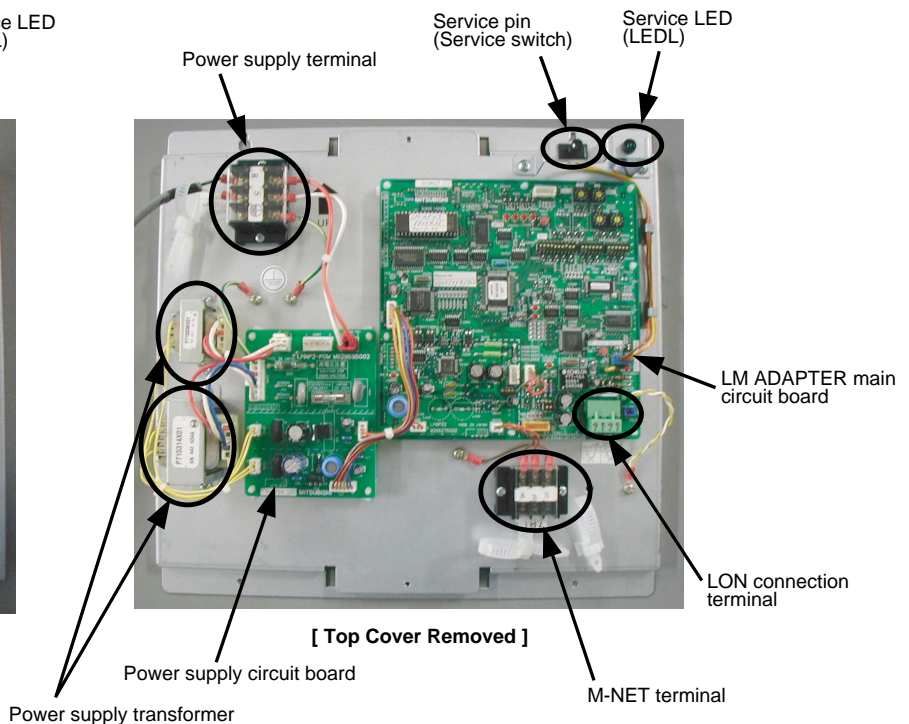

[Top Cover Removed]

Explanation of function switch

Note: Function switch setting of LM ADAPTER is different according to the management item of the equipment connected with LONWORKS® . Carefully set the system.

SW	Switch name	Function		Note	Factory setting	Set timing
SW1-1	Function switch of local prohibit	ON	local prohibit effective	Operation local prohibit nv input from LONWORKS® becomes Effective when switch is ON.	OFF	Before power supply
		OFF	local prohibit invalidity	Operation local prohibit nv input from LONWORKS® becomes invalid when switch is OFF.		
SW1-2	Used together with system controller switch	ON	used together with system controller		OFF	Before power supply
		OFF	not used together with system controller			
SW1-3	Indoor temperature state interval switch	ON	Transmission interval (1minutes or more)	*number of indoor units that should be connected is 30 or less	OFF	Before power supply
		OFF	Transmission interval (10 minutes or more)			
SW1-4	Reset filter sign/ Select enable/ disable operation duration	ON	Enable	When "ON", the reset filter sign input and the operation duration output are enabled.	OFF	Before power supply
		OFF	Disable	When "OFF", the reset filter sign input and the operation duration output are disabled.		
SW1-5	Function switch of LOSSNAY	ON	LOSSNAY is operated from LONWORKS®	Please turn on the switch when LOSSNAY is operation from LONWORKS®.	OFF	Before power supply
		OFF	LOSSNAY interlocks with the indoor unit	Please turn off the switch when LOSSNAY interlocks with the indoor units.		
SW1-7	Function switch of SNVT_switch	ON	SNVT Standard	When "ON", the specifications of the nv using the SNVT_switch comply with the SNVT Standards.	OFF	Before power supply
		OFF	Original	When "OFF", the nv using the SNVT_switch has original specifications.		
SW1-8	Select enable/ disable forced thermo OFF	ON	Enable forced thermo OFF	When "ON", the forced thermo OFF nv input/output are enabled.	OFF	Before power supply
		OFF	Disable forced thermo OFF	When "OFF", the forced thermo OFF nv input/output are disabled.		
SW1-9	Indoor units test run switch	ON	ON(test run) is transmitted to the indoor units		OFF	Always
		OFF	OFF is transmitted and indoor units stop test run			
SW3-2	Initialization switch of air conditioner units	ON	Connected cancellation command is transmitted to the indoor units		OFF	Always
		OFF	None			

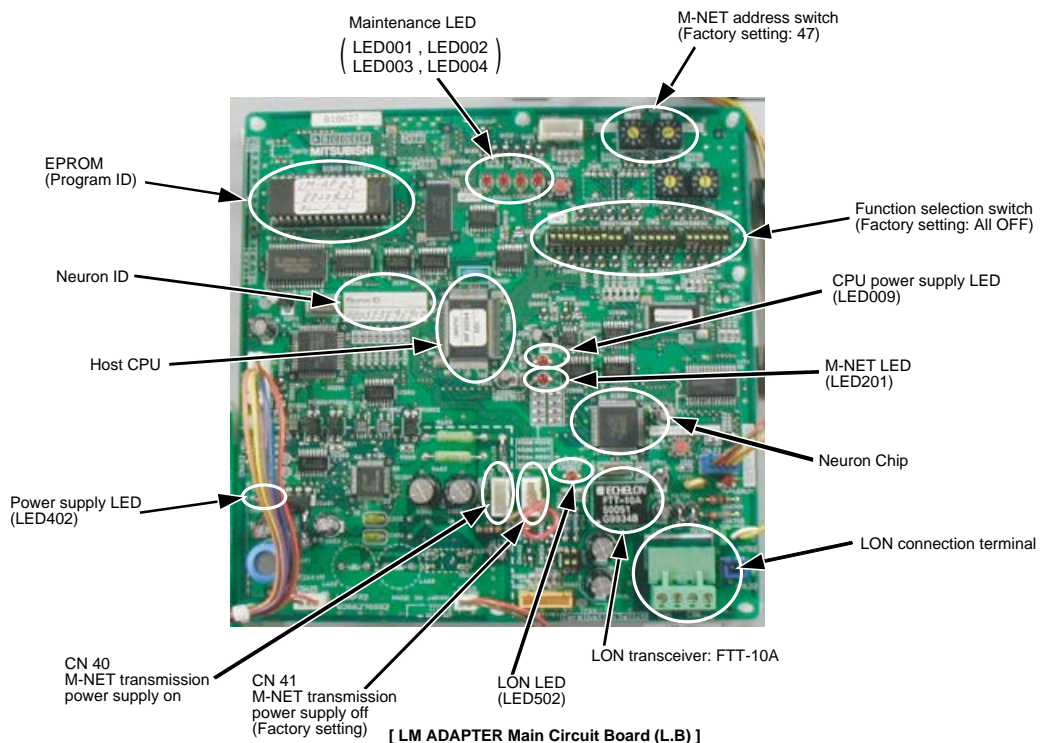

4. System Settings

This chapter only describes the system settings of this product.

For the installation work and electrical work, refer to the last chapter “ 3. Installation ”.

<Notes>

Read and understand the contents of Chapter 1 “Safety Precautions ” before performing the installation.

The system setting is different depending on the system configuration connected.

Check the system configuration.

1. When the system controllers are not used together.
2. When the system controllers are used together.

4-1 If not used together with system controller.

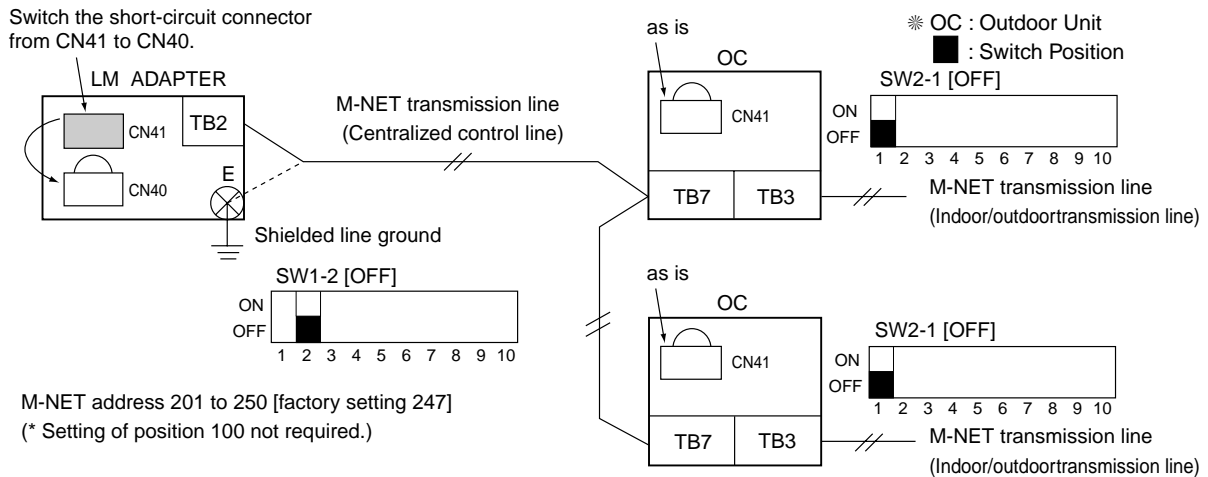

Item	Setting	Factory setting
M-NET address of LM ADAPTER	SWU2, 1 [201 to 250]	247
LM ADAPTER power switch connector	CN41 to CN40 (supplies power)	CN41
Combined switch for LM ADAPTER / system controller	SW1 - 2 [OFF] (Not used together with system controller)	OFF
OC central control (SC) on/off switch	SW2 - 1 [OFF] (No central control)	OFF
OC power supply connector	CN41 as is (power not supplied)	CN41

(Note 1) Change the LM ADAPTER power supply switch connector CN41 to CN40.

(Note:2)When connecting LOSSNAY, settings must be made in the LM ADAPTER.

- 1) Do not sequence LOSSNAY to the air conditioner. (Independent LOSSNAY)
Or when operation is to be controlled from LONWORKS® (BMS etc.) connected to the LOSSNAY remote controller.
LOSSNAY selection switch. (SW1-5)[ON]
- 2) When sequencing LOSSNAY to the air conditioner (sequenced LOSSNAY), and not controlling operation from LONWORKS®. (BMS etc.)
LOSSNAY selection switch. (SW1-5)[OFF]
When sequencing LOSSNAY to the air conditioner, the indoor unit and LOSSNAY sequence must be registered from the remote controller. (Refer to the remote controller installation manual for details on registering.)

(Note 3)When changing the system configuration, such as the M-NET address, always carry out the following steps.

- 1) Turn the LM ADAPTER service switch (SW2-1) [ON].
Change the LM ADAPTER system information delete switch (SW3-2) from [OFF] to [ON].
- 2) When erasing the system information, the maintenance LED “System Information Erase LED (LED001)” will turn ON.
- 3) When the system information has been erased, the maintenance LED “System Information Erase LED (LED001)” will turn OFF, and the maintenance LED “System Information Erase Complete LED (LED002)” will turn ON.
- 4) Turn the LM ADAPTER service switch (SW2-1) [OFF].
Change the LM ADAPTER system information delete switch (SW3-2) from [ON] to [OFF].
- 5) Turn the LM ADAPTER power OFF.
- 6) Make changes to change the unit system. (Addition of indoor unit, change of M-NET address, change of group, etc.)
- 7) To change the LM ADAPTER M-NET address and settings, carry out the changing work.
- 8) Turn the LM ADAPTER power ON.

(Note 4) Refer to the “System Design and Construction Manual” for the outdoor unit for details on the M-NET wiring length.

(Note 5) Set the M-NET address so that it is not duplicated with other units.

4-2 If used together with system controller.

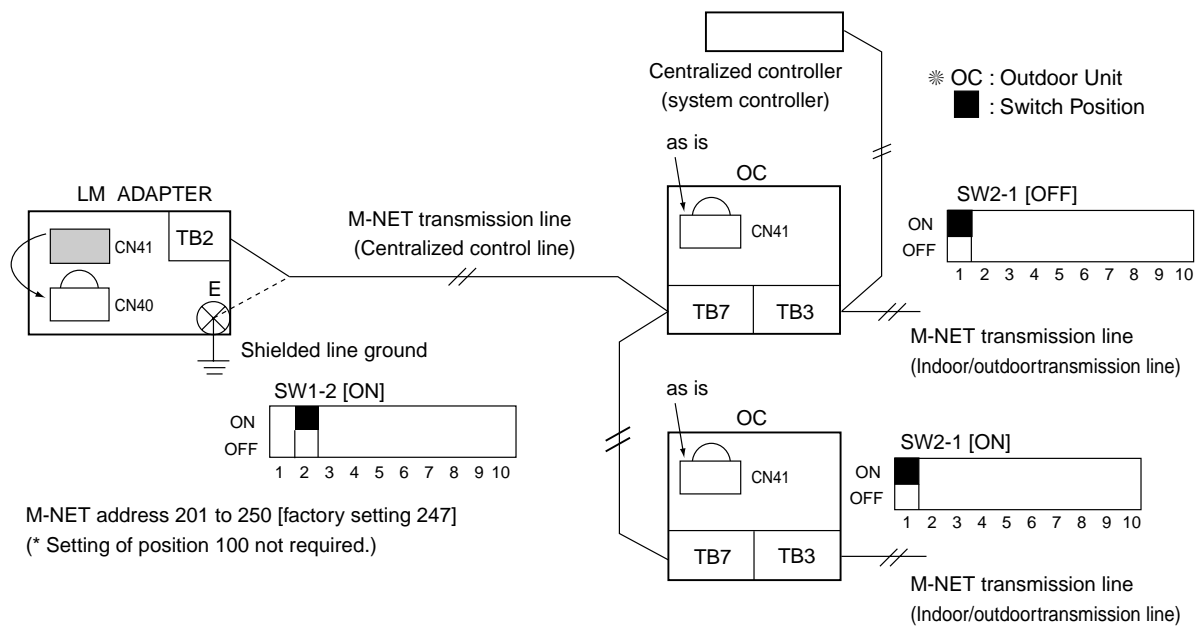

Item	Setting	Factory setting
M-NET address of LM ADAPTER	SWU2, 1 [201 to 250]	247
LM ADAPTER power switch connector	CN41 as is (power not supplied)	CN41
Combined switch for LM ADAPTER / system controller	SW1 - 2 [ON] (Used together with system controller)	OFF
OC central control (SC) on/off switch	SW2 - 1 [ON] (Central control)	OFF
OC power supply connector	CN41 as is (power not supplied)	CN41

(Note:1) When connecting LOSSNAY, register the sequence must be registered from the shared system controller.

(Note 2) When changing the system configuration, such as the M-NET address, system controller being shared must be registered or changed.

(Note 3) Refer to the "System Design and Construction Manual" for the outdoor unit for details on the M-NET wiring length.

(Note 4) Set the M-NET address so that it is not duplicated with other units.

4-3 Initialization Settings of LONWORKS® Network

For details, refer to “ FTT-10A Free Topology Transceiver User's Guide ” of Echelon Corporation. For reference, the system specifications and Transmission specifications are described.

(1) System Specifications

- Up to 64 FTT-10/FTT-10A transceivers are allowed per network segment.
- LPT-10 transceivers may be used on network segments with FTT-10/FTT-10A transceivers, but are subject to additional constraints, particularly on distance.
See the LPT-10 Use's Guide for more information.
- The average temperature of the wire must not exceed +55°C (+131°F), although individual segments of wire may be as hot as +85°C (+185°F).

(2) Transmission Specifications

Doubly-Terminated Bus Topology Specifications

	Maximum bus length	Units
Belden 85102	2700(8858)	meters (feet)
Belden 8471	2700(8858)	
Level IV 22AWG	1400(4593)	
JY(St)Y 2X2X0.8	900(2953)	
TIA Category 5	900(2953)	

Free Topology Specifications

	Maximum node-to-node distance	Maximum total wire length	Units
Belden 85102	500(1640)	500(1640)	meters (feet)
Belden 8471	400(1312)	500(1640)	
Level IV 22AWG	400(1312)	500(1640)	
JY(St)Y 2X2X0.8	320(1050)	500(1640)	
TIA Category 5	250(820)	450(1476)	

The free topology transmission specification includes two components which must both be met for proper system operation. The distance from each transceiver to all other transceiver and to the termination (including the LPI-10 termination, if used) must not exceed *maximum node-to-node distance*.

If multiple paths exist, e.g., a loop topology, then the longest path should be used for the calculations.

The *maximum total wire length* is the total amount of wire connected per segment.

5. Confirming Operation

5-1 Flow of Onsite Adjustments

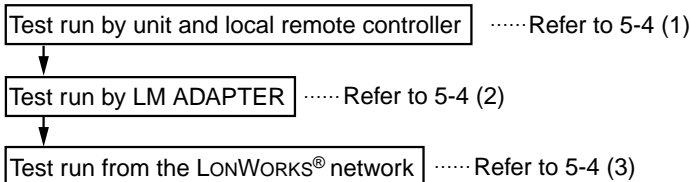

There are the following two methods to perform a test run from the LONWORKS® network.

- ① Test run by LONWORKS® tools
If the bindings to other machines have not been performed, use the LONWORKS® tools as described by the procedure given in 5-4 (3) and confirm that operation can be performed from a LONWORKS® network.
- ② Test run from building management system
If the bindings to other machines have been performed, or if you do not have the LONWORKS® tools, follow the building management system test run procedure to confirm that operation can be performed from the LONWORKS® network.

5-2 Preparation Material for Onsite Adjustments

(1) Preparation material for onsite adjustment

Tester
Onsite adjustment tools (LONWORKS® tools, M-NET onsite adjustment tools)

* LONWORKS® tools
The LONWORKS® tools are listed below. Contact your dealer for more information.

- LONWORKS® network interface (PCC-10 PC card etc.)
- Cables for the above interface
- nodeutil (Free software from Echelon)

(2) Reference materials

LM ADAPTER Installation Manual
LM ADAPTER Network Variable Specifications

5-3 Preparation and Settings

- (1) Perform the previous operations described in Chapter 3 “Installation”, Chapter 4 “System Settings”.
 - (2) If being used together with system controller, perform the installation and electrical installation for system controller.
 - (3) Perform the initial processing for the LM ADAPTER.
 - ① Turn on the power supply for LM ADAPTER.
 - ② If being used together with system controller, perform the initialization settings.
 - ③ The units will be idle until the LM ADAPTER initialization has been completed (LED002 goes out).
 - * This requires approximately 5 to 10 minutes. (If being used together with system controller, it will be approximately 3 minutes after the completion of the initialization settings.)
 - If you connect the power to the LM ADAPTER before connecting the power supply to the units, the LED002 might stay lit. If this case arises, reset the power supply to the LM ADAPTER.
 - ④ Confirm that the LM ADAPTER’S maintenance LED (LED003, 004) are not lit.
 - * If the LM ADAPTER’S maintenance LED (LED003, 004) are lit, refer to the next chapter “6. Troubleshooting”.
- (Note 1) Always refer to the previous chapter “4. System settings” before changing the system configuration, such as the M-NET address.**
* After confirming the above details, always refer to the following section “5-4 Test Run” and make confirmations with trial operations.
- (Note 2) Turn all of the switches in the service switch (SW2) [OFF] to confirm the ON/OFF status of the above maintenance LED (LED002, LED003 and LED004).
- (4) After confirming the above, always perform the test run as described in the next section “5-4. Test Run”.

5-4 Test Run

Perform the test run according to the test procedure of the test run check list.

(1) Test run of units by local remote controller

- ① Perform the test run of the units by using the local remote controller or system controller.
- * Confirm that all units are running normally.

(2) Test-operation of the indoor unit from LM ADAPTER

- ① Turn on SW1-9 of LM ADAPTER.
- * If there is even one indoor unit that is not running, the LM ADAPTER may not correctly recognize the indoor unit. Refer to the next chapter “ Troubleshooting ”.
- ② Finally turn OFF SW1-9, and verify that all indoor units are stopped.

(3) Test-operation of the indoor unit from LONWORKS®

If there is any tool which corresponds to LONWORKS®, verify that it can be operated from LONWORKS® network according to the following procedure.

- ① Set the LM ADAPTER in config .
- If LM ADAPTER has been already bounded to another model (the service LED is not ON), don't apply any new binding.
- ② During the test operation, use “ nv1n Request ON/OFF ” to verify that the indoor unit can be operated. For details of “ nv1n Request ON/OFF ” , refer to the following.

nv1n Request ON/OFF command input

network input SNVT_switch nviOnOff_n;

This input network variable is used to allow On request or Off request of the indoor unit to be changed via the network.

When the ventilator (LOSSNAY) Interlocks with the indoor unit, it becomes the same operation as the indoor unit.

Valid range (SW1-7 OFF)

value field: not used

state field: 0 = indoor unit or ventilator unit is “ OFF ”

state field: 1 = indoor unit or ventilator unit is “ ON ”

: Else = Indoor unit or ventilator unit is “ OFF ”

_n: ----- Indoor unit address (M-NET)

* Refer to the index in the table below when performing update and poll (confirm state) of the network variable for the LONWORKS® tools (nodeutil etc.).

ON/OFF Request		ON/OFF run state	
index	nv name	index	nv name
1	nviOnOff_001	51	nvoOnOff_001
2	nviOnOff_002	52	nvoOnOff_002
:	:	:	:
49	nviOnOff_049	99	nvoOnOff_049
50	nviOnOff_050	100	nvoOnOff_050

- ③ Finally put the LM ADAPTER in the unconfig, and end the test operation. Contact your dealer for details on trial operation from the LONWORKS® network.

6. Troubleshooting

6-1 Abstract

If LM ADAPTER does not properly operate, first check the following contents.

Item	Normal state	Contents to check
LED009 (WDT)	ON	Check the Main Power Switch to the LM ADAPTER is not turned off, any connectors (CN605, CN65, CN32, CN33, CN31, CN71) are disconnected and for a blown fuse (F).
LED402 (5VM)	ON	Check the Main Power Switch to the LM ADAPTER is not turned off, any connectors (CN405, CN45, CN21, CN31, CN71) are disconnected and for a blown fuse (F).
LED502 (3150RST)	OFF	The LM ADAPTER'S initial processing has not been completed. Wait for 15 minutes after the power supply is turned on (Until the initializing process is completed).
LED201 (18007RST)	OFF	The LM ADAPTER'S initial processing has not been completed. Wait for 2 minutes after the power supply is turned on (Until the initializing process is completed).
Service LED	—	It blinks when it is not binding. At this time, operation is unavailable from the network side from LONWORKS®. Binding the equipment which corresponds to LONWORKS® network.
LED002	OFF	If it is ON when the dip switch SW2 are all OFF, the LM ADAPTER is incompletely initialized. Wait for 15 minutes after the power supply is turned on (Until the initializing process is completed).
LED003	OFF	If it is ON when the dip switch SW2 are all OFF, check the setting of the switches and so on, and turn on the power supply again.
LED004	OFF	If it is ON when the dip switch SW2 are all OFF, there may be trouble at the indoor unit. Check the connection and setting of all indoor units.
CN40/41	—	If the power supply unit is connected, insert the jumper connector to CN41. If the power supply unit is not connected, insert the jumper connector to CN40.
SW71	—	LONWORKS® The switch sets the termination of LONWORKS® network. According to the system design of LONWORKS® network, check whether it is properly set or not.
M—NET Address switch SWU1, SWU2	—	If system controller is used, check whether M-NET address is overlapped or not. Initial setting of LM ADAPTER is 247.
Dip switch SW1, SW2, SW3	—	Check whether system controller is present or not (SW1-2), and whether the independent/combined LOSSNAY (SW1-5) is properly set or not. Moreover, verify that all other switches are all off.

6-2 Troubleshooting

No.	Error content	Cause	Checking method and remedy
1	LED002 is ON	<p>(1) It takes time for the initial processing to complete (normal).</p> <p>(2) Setting on M-NET side is not properly completed.</p> <p>(3) M-NET power supply switch has not been set.</p> <p>(4) The power supply to the air conditioner unit is disconnected.</p>	<p>It can take about 15 minutes for the initial processing to complete. Wait until the initial processing finishes.</p> <p>Verify that the test operation of the air conditioner is properly completed. Verify that M-NET transmission line is properly connected.</p> <p>Follow the instructions in "4. System Setting" and check the power supply unit setting, and the LM ADAPTER power supply switch connector setting.</p> <p>Verify that the air conditioner unit power supply is not disconnected. * Use a tester to check the voltage of the terminal (TB2). DC17-30 V</p>
2	The air conditioner unit does not operate even by performing a test run using the LM ADAPTER'S switch SW1-9.	<p>(1) The LM ADAPTER is not completely initialized.</p> <p>(2) Setting on M-NET side is not properly completed.</p> <p>(3) If system controller is used together LM ADAPTER is not registered to system controller.</p>	<p>Turn OFF all SW2. After verifying that LED002 is OFF, test the operation again.</p> <p>Verify that the test operation of the air conditioner is properly completed. Verify that M-NET transmission line is properly connected.</p> <p>In system controller, register LM ADAPTER as the sub system controller.</p>
3	The LOSSNAY unit does not operate even by performing a test run using the LM ADAPTER'S switch SW1-9.	<p>(1) The LM ADAPTER is not completely initialized.</p> <p>(2) Setting on M-NET side is not properly completed.</p> <p>(3) If system controller is used in combination, LM ADAPTER is not registered to system controller.</p> <p>(4) The independent/combined LOSSNAY of LM ADAPTER is not set.</p>	<p>Refer to 2-(1).</p> <p>Refer to 2-(2).</p> <p>Refer to 2-(3).</p> <p>Turn on SW1-5 of LM ADAPTER, and reset the power supply.</p>
4	Even if it is operated with the remote controller/system controller, it is not informed to the host on LON side.	<p>(1) The LM ADAPTER is not completely initialized.</p> <p>(2) Setting on M-NET side is not properly completed.</p> <p>(3) If system controller is used in combination, LM ADAPTER is not registered to system controller.</p> <p>(4) LONWORKS® network transmission line is not properly connected.</p> <p>(5) The termination of LONWORKS® network is not properly set.</p> <p>(6) Binding of LONWORKS® network is not properly ended.</p>	<p>Refer to 2-(1).</p> <p>Refer to 2-(2).</p> <p>Refer to 2-(3).</p> <p>Check for disconnection on TB21, short-circuit and wire breakage on the network wire and so on.</p> <p>Verify that the termination of LONWORKS® network is properly set according to the system design.</p> <p>Apply the binding again.</p>

	Error content	Cause	Checking method and remedy
5	Independent/combined LOSSNAY can not be operated from the LON side.	<p>(1)The LM ADAPTER is not completely initialized.</p> <p>(2)Setting on M-NET side is not properly completed.</p> <p>(3)If system controller is used together LM ADAPTER is not registered to system controller.</p> <p>(4)The independent/combined LOSSNAY of LM ADAPTER is not set.</p> <p>(5)LONWORKS® network transmission wire is not properly connected.</p> <p>(6)The termination of LONWORKS® network is not properly set.</p> <p>(7) Binding of LONWORKS® network is not properly ended.</p>	<p>Refer to 2-(1).</p> <p>Refer to 2-(2).</p> <p>Refer to 2-(3).</p> <p>Refer to 3-(4).</p> <p>Refer to 4-(4).</p> <p>Refer to 4-(5).</p> <p>Refer to 4-(6).</p>
6	Air conditioner can not be operated from the LON side.	<p>(1)The LM-ADAPTER is not completely initialized.</p> <p>(2)Setting on M-NET side is not properly completed.</p> <p>(3)If system controller is used together LM ADAPTER is not registered to system controller.</p> <p>(4)LONWORKS® network transmission wire is not properly connected.</p> <p>(5)The termination of LONWORKS® network is not properly set.</p> <p>(6) Binding of LONWORKS® network is not properly ended.</p>	<p>Refer to 2-(1).</p> <p>Refer to 2-(2).</p> <p>Refer to 2-(3).</p> <p>Refer to 4-(4).</p> <p>Refer to 4-(5).</p> <p>Refer to 4-(6).</p>
7	Prohibit local remote controller operation cannot be set from the LON side.	(1) Perform the LM ADAPTER'S prohibit local remote controller operation setting.	Turn on SW1-1 of LM ADAPTER, and reset the power supply.
8	Forced thermo OFF cannot be set from the LON side.	(1) Perform the LM ADAPTER'S forced thermo OFF setting.	Turn on SW1-8 of LM ADAPTER, and reset the power supply.

6-3 Error code list

Error code	Display of trouble	Error content	Symptom	Cause	Checking method and remedy
6600	M-NET remote controller, MA remote controller, system controller	M-NET duplication error	<ul style="list-style-type: none"> If it has been confirmed that a unit with the same M-NET address is transmitting. 	<ul style="list-style-type: none"> If there are two or more units with the same M-NET address at the unit and controller. 	<ul style="list-style-type: none"> Check that there are no duplicate addresses. After correcting problem, reset power supply.
6601	M-NET remote controller, MA remote controller, system controller	M-NET polarity not set error	<ul style="list-style-type: none"> When discrimination of the polarity of the M-NET transmission wire. 	<ul style="list-style-type: none"> Interrupted power supply, Connectors (CN405, CN45, CN21, CN71). Damage to transformer (T2). Interrupted power supply for M-NET transmission wire. 	<ul style="list-style-type: none"> Check for defects. Once corrected, reset the power supply.
6607	M-NET remote controller, MA remote controller, system controller or building control system	No ACK error	<ul style="list-style-type: none"> If there is no response (ACK) from the recipient after a transmission. 	<ul style="list-style-type: none"> If recipient of transmission is LM ADAPTER. Defect in transmission line (TB2)between LM ADAPTER. Interrupted power LM ADAPTER power supply (TB1). Blown fuse (F1) in LM ADAPTER disconnection on the loose connector (CN605, CN65, CN32, CN33, CN31). Damage transformer in LM ADAPTER (T1, T2). Damage circuit board (L.B, P.B). 	<ul style="list-style-type: none"> Check these areas. After correcting problem, reset power supply.
7702	M-NET remote controller, MA remote controller, system controller	M-NET connection error (no connection to indoor unit or LOSSNAY unit)	Could not connect to any indoor units or LOSSNAY units.	<ul style="list-style-type: none"> Power supply is not connected to indoor unit or LOSSNAY unit. M-NET transmission cable is not connected. Power supply is not connected to M-NET transmission cable. 	<ul style="list-style-type: none"> Check these areas. After correcting problem, reset power supply.
7703	M-NET remote controller, MA remote controller, system controller	M-NET connection error (no connection to master system controller)	DIP SW1-2 is OFF and the system controller is connected. DIP SW1-2 is ON and the system controller is not connected.	<ul style="list-style-type: none"> M-NET transmission cable is not connected. Power supply is not connected to M-NET transmission cable. The DIP SW1-2 setting is different to the system configuration. 	<ul style="list-style-type: none"> Check these areas. After correcting problem, reset power supply.
7705	M-NET remote controller, MA remote controller, system controller	Initialization error	Initialization of the LM ADAPTER failed.	Damage in LM ADAPTER.	Reset the power supply. If the same error occurs again, the controller is faulty.

Appendix : Test run check sheet

Test run check sheet

Unit address	Test run of units (SW1-9)		Operation from LONWORKS® network				Confirmation of operating status						MEMO
	ON	OFF	ON	OFF	Operation mode	Set temperature	ON	OFF	Operation mode	Set temperature	Error	Intake temperature	
01													
02													
03													
04													
05													
06													
07													
08													
09													
10													
11													
12													
13													
14													
15													
16													
17													
18													
19													
20													
21													
22													
23													
24													
25													
26													
27													
28													
29													
30													
31													
32													
33													
34													
35													
36													
37													
38													
39													
40													
41													
42													
43													
44													
45													
46													
47													
48													
49													
50													

* Check the building control system functions beforehand and check off each operation as it is tested.
 For the check list, you can either copy this sheet or make a new check list based on this sheet.

NOTE: This equipment has been tested and found to comply with the limits for a Class B digital device, pursuant to Part 15 of the FCC Rules. These limits are designed to provide reasonable protection against harmful interference in a residential installation. This equipment generates, uses and can radiate radio frequency energy and, if not installed and used in accordance with the instructions, may cause harmful interference to radio communications. However, there is no guarantee that interference will not occur in a particular installation. If this equipment does cause harmful interference to radio or television reception, which can be determined by turning the equipment off and on, the user is encouraged to try to correct the interference by one or more of the following measures:

- Reorient or relocate the receiving antenna.
- Increase the separation between the equipment and receiver.
- Connect the equipment into an outlet on a circuit different from that to which the receiver is connected.
- Consult the dealer or an experienced radio / TV technician for help.



HEAD OFFICE MITSUBISHI DENKI BLDG. MARUNOUCHI TOKYO 100-0005 TELEX J24532 CABLE MELCO TOKYO

WT03760X01